

# Extreme duty bumper pull deck over - XDB

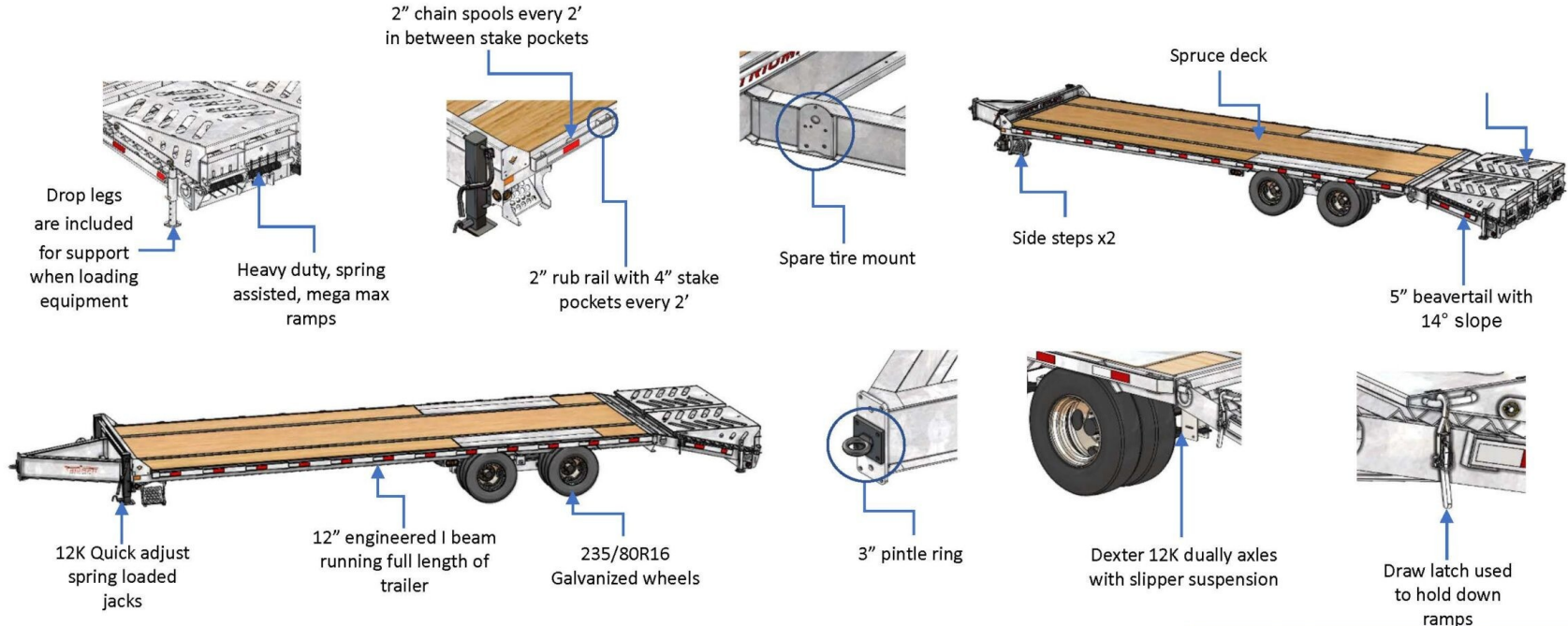

Trailer size	Trailer code	Deck length	Deck width	Deck height	GVWR	Payload capacity	Trailer weight
8' X 20' + 5'	GHDEF1	20'	102"	34" (low profile)	26,400 LBS	19,125 LBS	7,275 LBS



### Additional options:

- Winch tracking
- 15K axle upgrade
- Hydraulic brake upgrade
- Hydraulic ramps
- Spare tire
- Tandem 2-speed jacks
- Tandem hydraulic jacks
- Hutch suspension
- Undermount toolboxes

### Additional information:

- Electric brakes on all axles
- 3" C-channel at 16" centers supported by deck braces underneath
- Heat shrink connectors on wire harnesses provide insulation and waterproof connections
- LED lighting
- Hot dip galvanizing offers greater protection and prevents the formation of rust

### Hot Dip Galvanizing Process

First, the product is dipped in acidic solution and rinsed with cold water to remove the grease, dirt, rust and scale. It is then dipped in a flux solution to remove the last traces of oxide and to wet the steel. When the clean iron is then dipped into a molten zinc solution (typically at 450°C), it forms zinc-iron layers by a metallurgical reaction between the iron and zinc.

### Dealer Contact Information

Work phone: 810 346-2835  
 Email: [Benstrailersales@benssupercenter.com](mailto:Benstrailersales@benssupercenter.com)  
 Website: [www.Bensgreatlakessales.com](http://www.Bensgreatlakessales.com)  
 Location:

